



Safety Analysis of the 3 main parts in the CO₂ system

Nikhef number: 39300-MT-00001	Item number: AA1578	Date: 11/11/2010 Status: In Work	Page: 1 of 38 Revision: A.3
---	-------------------------------	--	---------------------------------------

Project: **LHCb VELO**

Department: **Mechanical Technology**

Top folder: **CO₂ cooling**

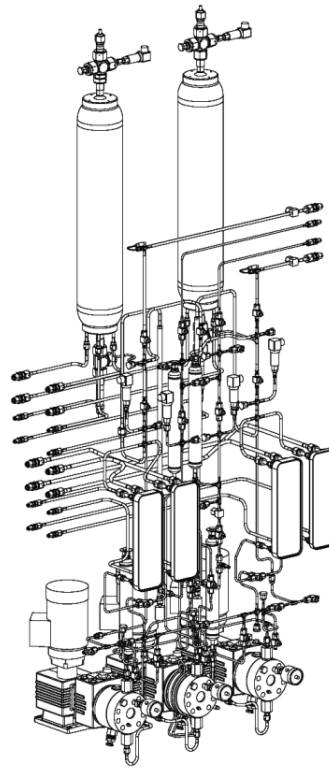

Created by:
M.J. Kraan

Checked by:
C. Snippe, M. Doets

Approved by:

Abstract:

The scope of this document is the safety verification of the 3 main parts (accumulator, reinforced plates of the heat exchanger and damper) in the LHCb VELO CO₂ cooling system which will be used at CERN (Geneve). The system has to comply with the Pressure Equipment Directive (PED) 97/23/CE. The French construction code for pressure apparatus CODAP (Code De Construction des Appareils a Pression) is used to verify the stresses. With a volume of 13.9 liter and a design pressure of 130 bar, the two accumulator vessels are classified in PED category III.

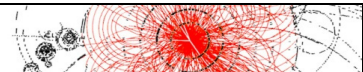

Table of Contents

1	<i>Introduction</i>	3
2	<i>General description of the cooling system</i>	4
2.1	Principle of the system	4
2.2	Design of the cooling system	6
3	<i>Defining PED Category and Module</i>	11
3.1	Accumulator	11
3.2	Heat exchanger with reinforced plates	12
3.3	Damper	12
4	<i>Calculations (Finite element analysis)</i>	14
4.1	Accumulator	14
4.1.1	Operational conditions	15
4.1.2	Material	16
4.1.3	Calculation accumulator tube	17
4.1.4	Stress and deformation analysis	18
4.2	Reinforced plates of the heat exchanger	21
4.2.1	Operational conditions	21
4.2.2	Material	22
4.2.3	Stress and deformation analysis	23
4.2.4	Calculation of the bolts	27
4.3	Damper	28
4.3.1	Operational conditions	28
4.3.2	Material	29
4.3.3	Stress and deformation analysis	30
4.4	Results of the analysis	33
4.4.1	Accumulator	33
4.4.2	Reinforced plates of the heat exchanger	33
4.4.3	Damper	33
5	<i>Tests, safety and quality control</i>	34
5.1	Tests before installation at CERN	34
5.2	Tests at CERN	34
5.3	Safety	35
5.3.1	Safety valves	35
5.3.2	Personal safety	35
5.3.3	Internal interlocks and protections	35
5.4	Quality control	37
6	<i>Summary</i>	38

1 Introduction

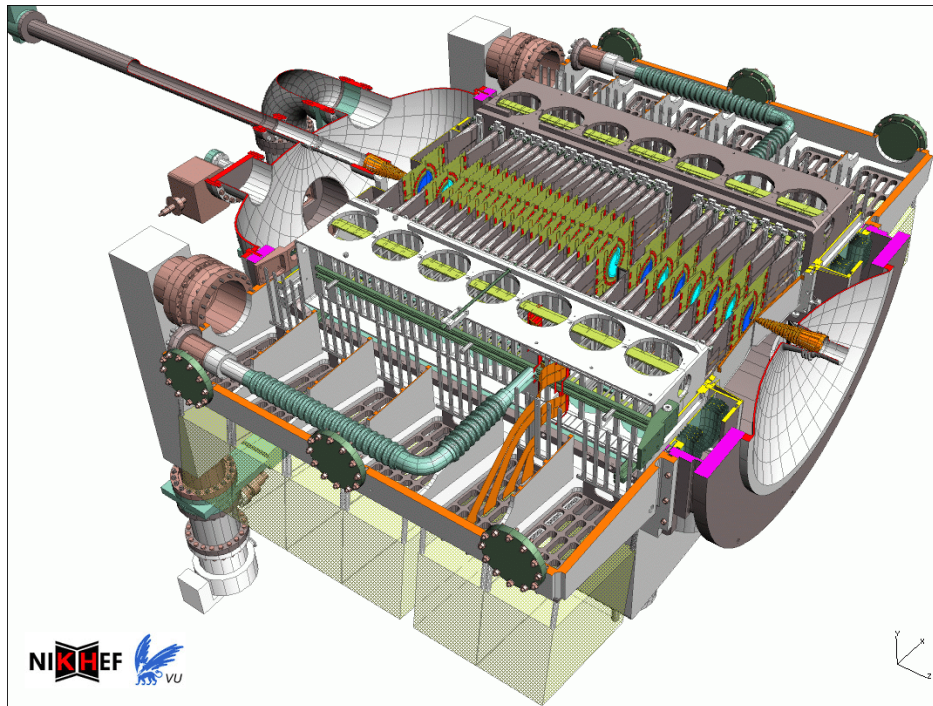

Figure 1. Vertex Locator of the LHCb experiment

The LHCb-Vertex LOcator Experiment (VELO) at the CERN's Large Hadron Collider (LHC) requires accurate thermal control of the silicon sensors. The readout electronics of the sensors produce the heat which a cooling system should remove. Construction material used inside silicon detectors must be of low mass and tolerant to ionizing radiation. To suppress radiation damage of the silicon detectors, the silicon must be kept cold to sub-zero temperatures at all times. All the silicon sensors need to have equal temperatures within 1 or 2 degrees to avoid thermal stresses. The requirements of the cooling system for the LHCb VELO detector have led to the use of CO₂ as evaporative cooling fluid. CO₂ was selected as coolant because of the radiation hardness and the proper 2-phase temperature range. The temperature in the evaporator is controlled by a 2-phase accumulator control mechanism which is used in capillary pumped loop systems

The scope of this document is the safety of the three main components in the CO₂ cooling plant. The safety requirements are put forward by the Safety Commission (SC) at CERN. The system has to comply with the Pressure Equipment Directive (PED) 97/23/CE. The French construction code for pressure apparatus CODAP (Code De Construction des Appareils a Pression) is used to verify the stresses.

The document is structured as follows:

Chapter 2 gives a general description of the cooling system.

Chapter 3 defines the PED Category and Module.

Chapter 4 describes the finite element analysis to verify this with CODAP.

Chapter 5 describes the test and safety steps.

Chapter 6 gives a summary of the document.

2 General description of the cooling system

Described are the system in general, its main components, the conditions under which the system is operated, the material selected for the system and the classification of the system in correspondence with the CODAP.

2.1 Principle of the system

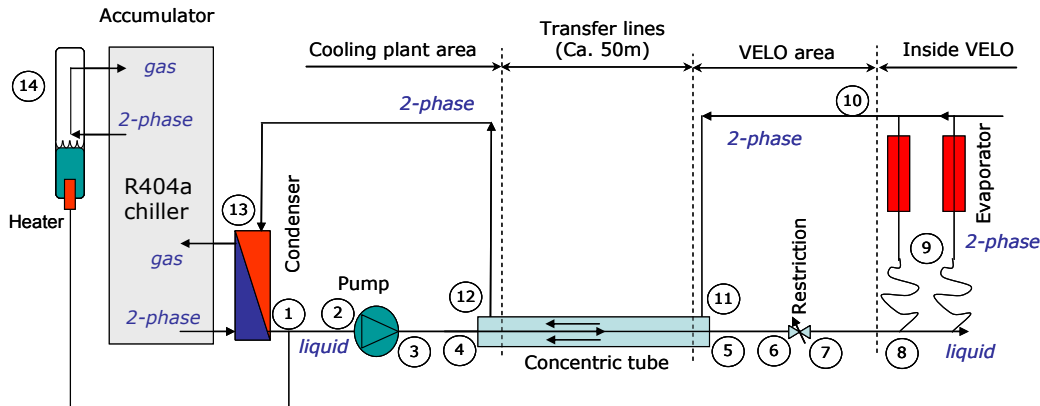

Figure 2. Simplified VTCS layout

Figure 2 shows a schematic diagram of the VELO Thermal Control System (VTCS). See appendix G for the system schematics. A mechanically pumped CO₂ loop is cooling the VELO detector by evaporating low quality CO₂. The vapor is condensed by a chiller with R507a as refrigerant. The condensed liquid is pumped by a liquid pump back towards the detector. The evaporator and condenser work at the same pressure. The pressure drop of the vapor return line is low. In this way the evaporator pressure can be controlled in the cooling plant which is away from the evaporator in the detector.

The pressure is controlled by the 2-phase accumulator which is parallel connected between the condenser and the pump. The accumulator contains a saturated liquid-vapor mixture. The temperature of the saturated mixture in the accumulator is regulated, controlling the accumulator pressure hence the condenser and evaporator pressure. The pressure regulation of the accumulator is a combination of heating and cooling. An electrical heater is evaporating liquid CO₂ causing the pressure to increase, an evaporator branch of the primary R507a chiller is condensing CO₂ vapor causing the pressure to decrease.

In order to ensure sub-cooling of the CO₂ before the liquid pump, the accumulator temperature must be higher than the condenser temperature. The sub-cooled state will prevent the pump from cavitations, a common problem in mechanically pumped 2-phase loops. The sub-cooled liquid is however too cold to be injected into the evaporator, because evaporators require saturated liquid. To heat the liquid up to saturation, a heat exchanger between the liquid inlet and vapor outlet of the evaporator is used.

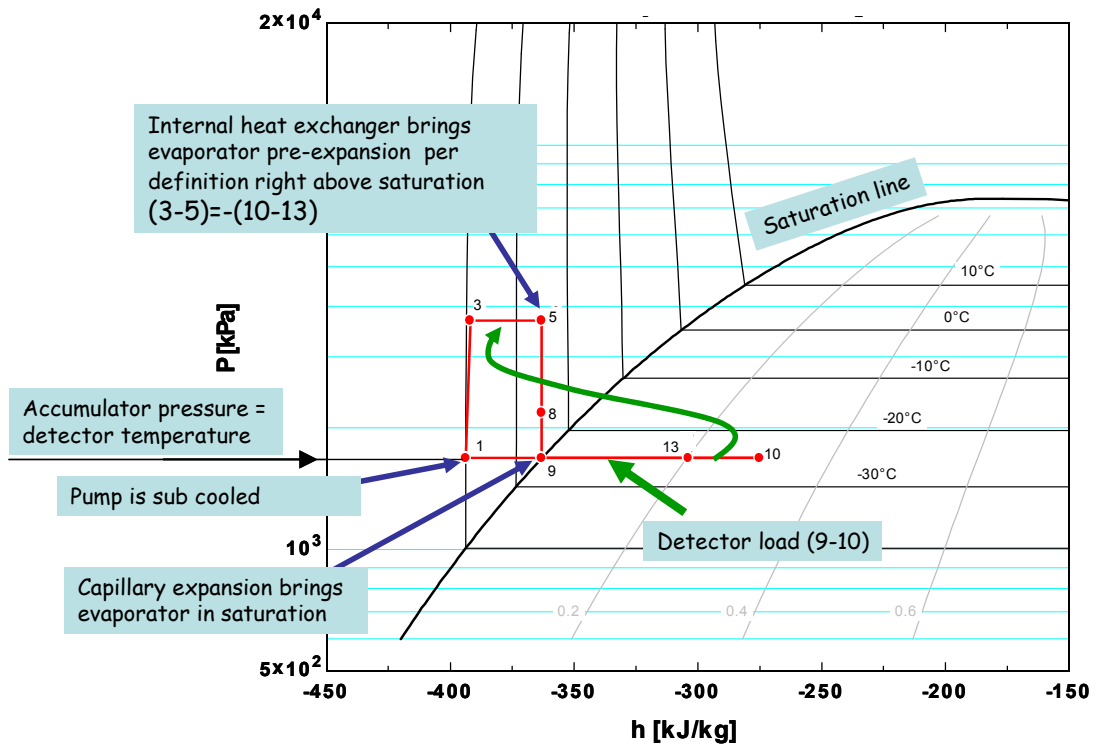

Figure 3. The 2-phase accumulator controlled loop in the P-h diagram

The absorbed heat in the evaporator is used to heat the sub-cooled flow so no extra heat is needed. Figure 3 shows the schematic of Figure 2 in the P-h diagram of CO₂. The numbers indicated in the diagram (1-13) correspond to the same numbers in Figure 2.

2.2 Design of the cooling system

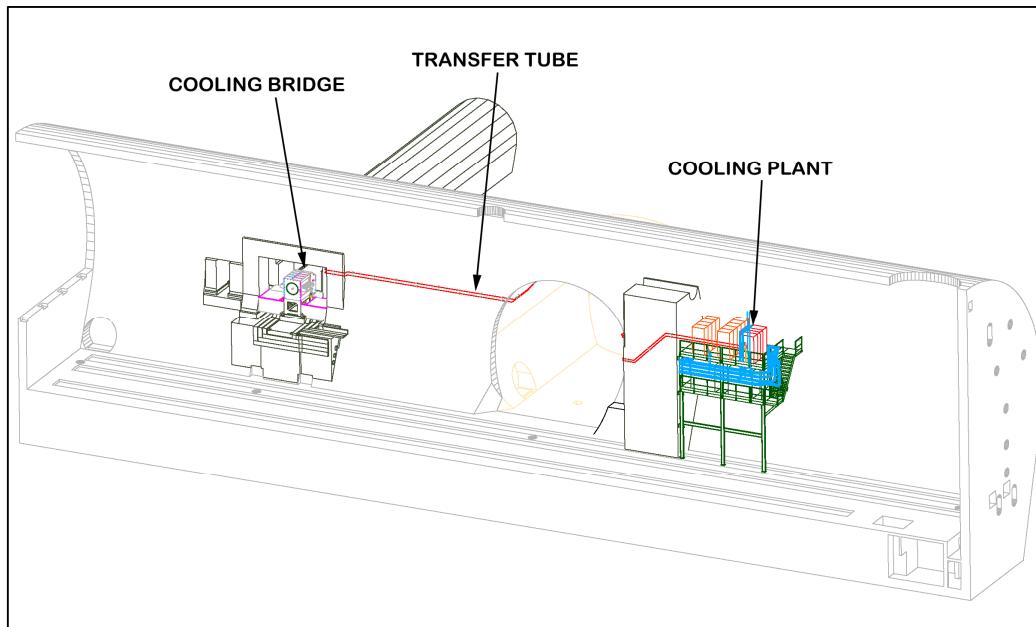

Figure 4. The VTCS cooling system

The VTSC system consists of three parts. An overview can be found in Figure 4. The cooling plant, located on platform UXA-C3, contains the Freon and CO₂ rack. It produces the right CO₂ temperature for the VELO detector. An overview of the schematics and different components used in the cooling plant can be found in appendices G and H. The system is controlled by a PLC, running on UPS, also situated in this platform. The CO₂ is transferred by two transfer tubes from the platform to the cooling bridge (see Figure 5) over the VELO in the alcove. These are concentric tubes of about 50m. The cooling bridge above the VELO vessel divides the CO₂ to the two evaporators, contained in the vacuum vessel.

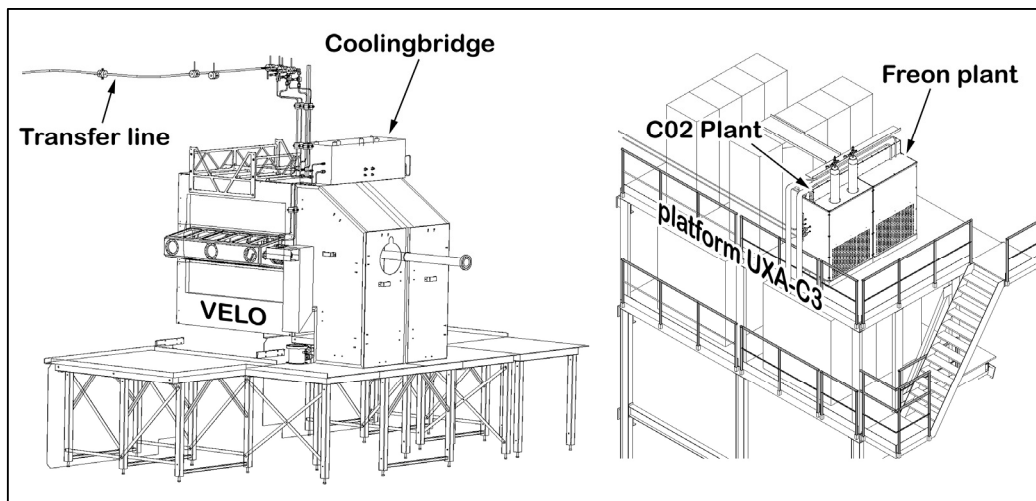

Figure 5. Closer view of the VTCS cooling system

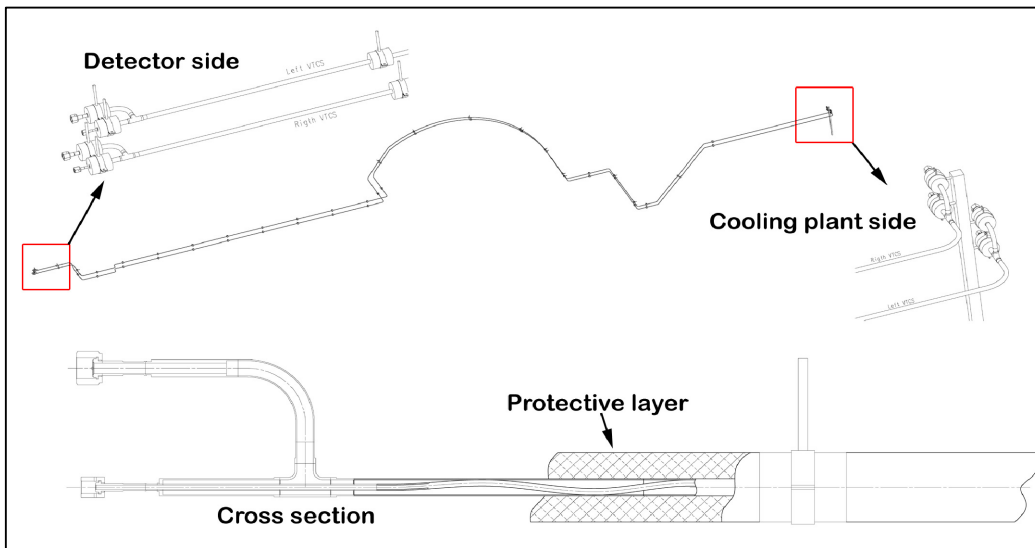

Figure 6. Transfer tube

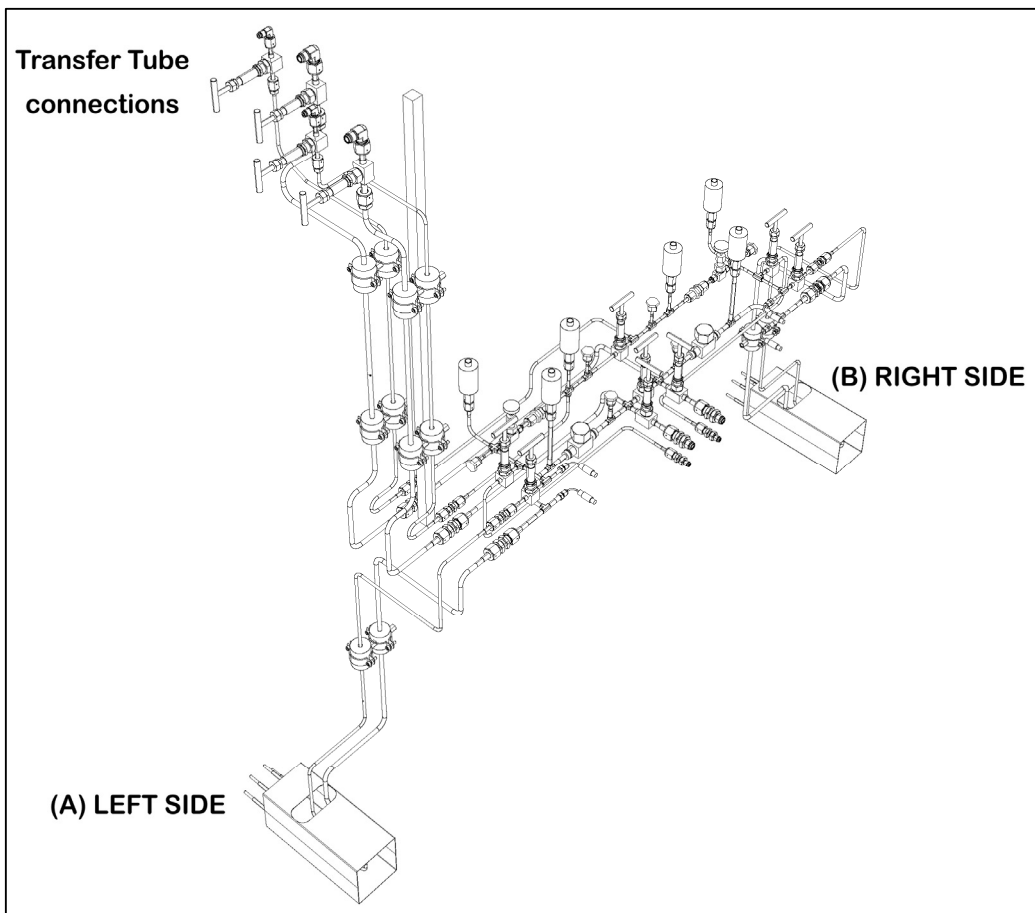

Figure 7. Cooling bridge

Due to the fact that the cooling bridge and transfer tube are mainly build with standard tubes, the FEA simulations are concentrated to three main components in the CO₂ plant: accumulator, damper and the reinforced plates of the heat exchanger, see Figure 8.

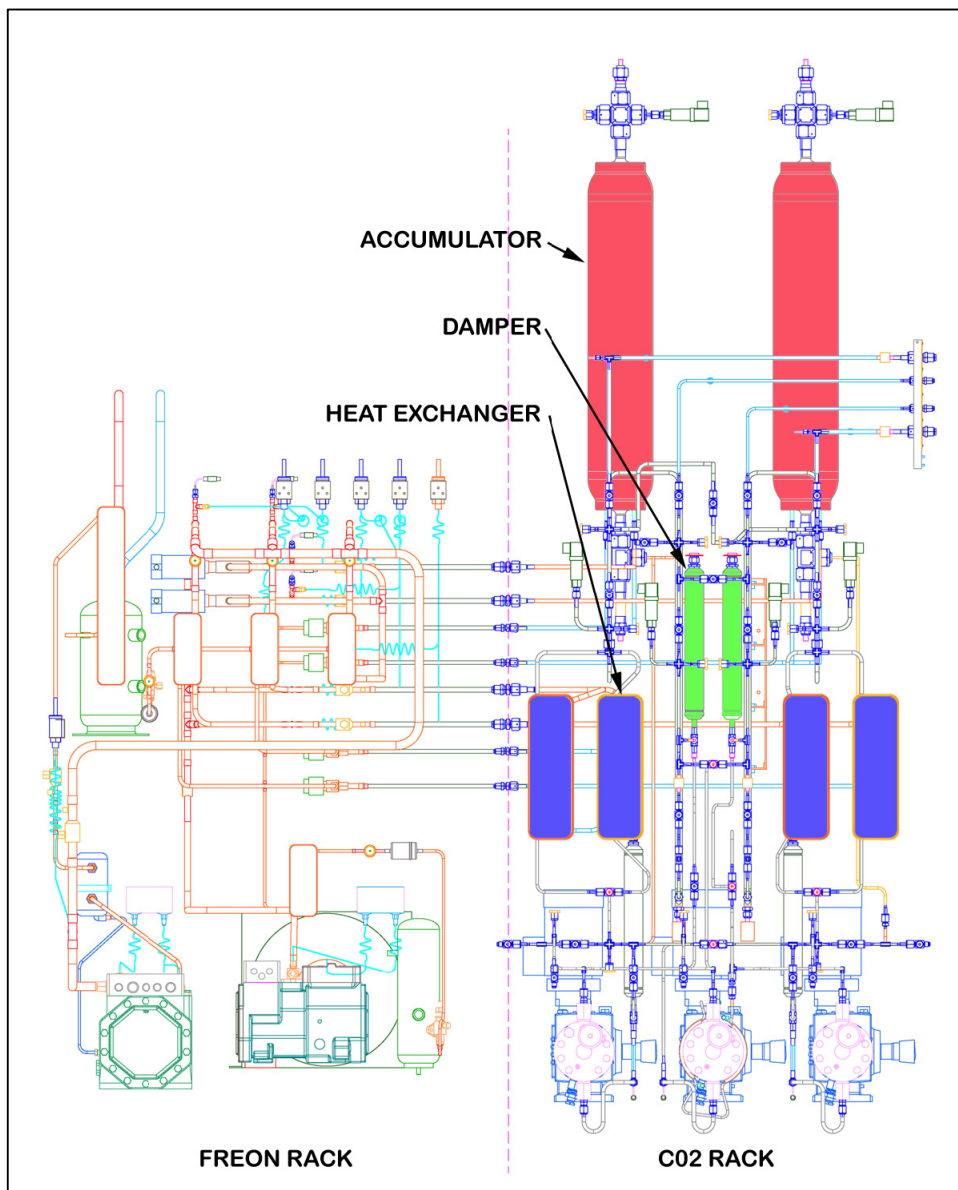

Figure 8. front view of the cooling plant

The load of the system is determined by the pressure of CO₂ which is related to the temperature. The system is operated at temperatures between +30 and -50 degrees Celsius. Typical pressure in the CO₂ system is 10-75 bar. Due to flow resistance in the system the maximum pressure after CO₂ pumps can be increase up to 100 bar. Burst discs and three relief valve should protect the system against failure of the cooling system. These burst discs are placed in volumes which can be enclosed by valves (manual and automatic valves controlled by the PLC). See paragraph 5.3.3 for details about the safety aspects in the PLC. The three relief valves are placed right after the LEWA CO₂ pumps. These pumps have an automatic internal safety overflow which is adjusted at 100 bar when it pumps to a closed volume (this happens rarely because it's prevented by the PLC). Pressure tests at Nikhef shows that right after the pump the first pressure peaks of the 'safety overflow' of these CO₂ pumps rises above the 130 bar due to this internal overflow mechanism and the incompressibility of the fluid. See appendix I for a summary of the technical drawings. Different parts of the cooling plant are shown in Figure 9 to 18.

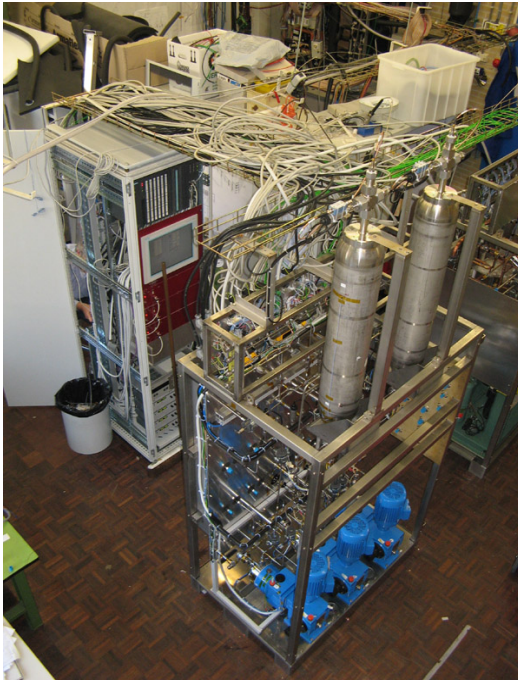

Figure 9. PLC rack and the CO₂ plant



Figure 10. Freon plant

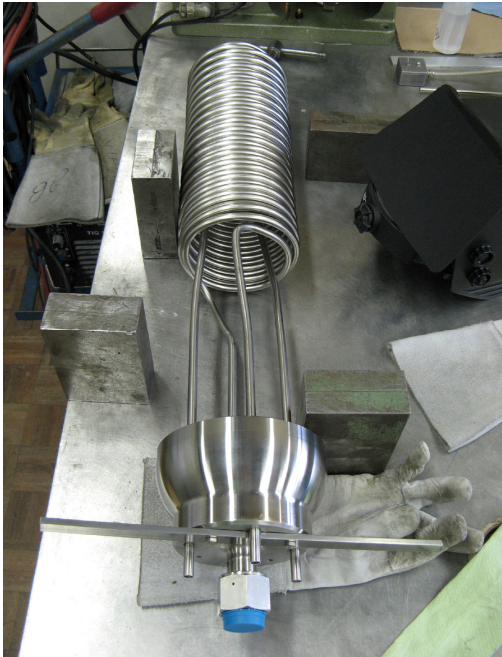

Figure 11. Accumulator cooling coils



Figure 12. Two accumulators mounted in cooling plant

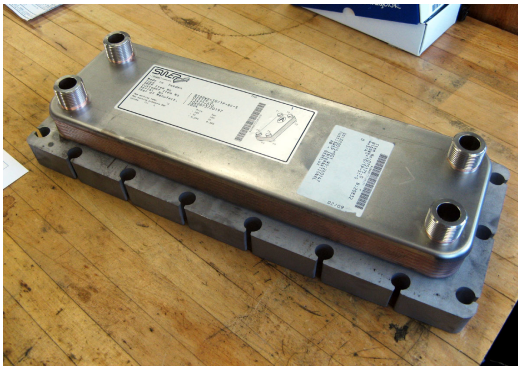

Figure 14. SWEP Heat exchanger

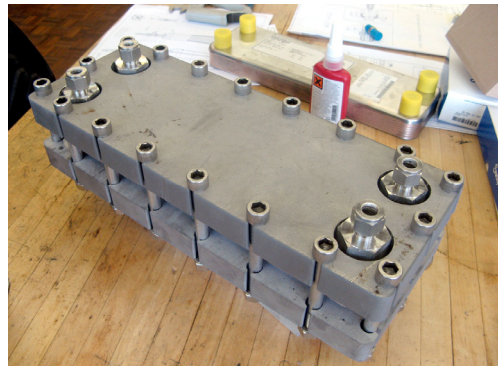

Figure 13. Heat exchanger between the re-inforced plates

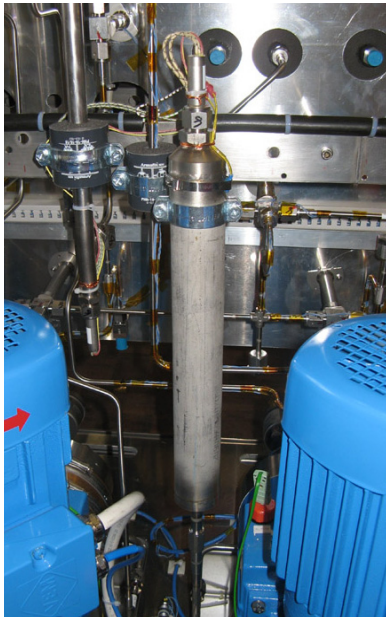

Figure 16. One Damper



Figure 15. Two dampers with isolation



Figure 17. Two Isolated heat exchanger



Figure 18. Two isolated accumulators

An overview of the all components is given in appendix H.

3 Defining PED Category and Module

The Pressure Equipment Directive (97/23/EC) was adopted by the European Parliament and the European Council in May 1997. The PED lays down requirements for the design and manufacture of pressure equipment and assemblies with a maximum allowable pressure greater than 0.5 bar gauge (1.5 bar absolute).

3.1 Accumulator

Pressure equipment: Pressure vessel
 Media: Carbon dioxide
 Group: Non dangerous media
 Phase: Gas
 Vessel volume: $V = Volume_{vessel} - Volume_{coil} = 15.5 - 1.6 = 13.9 \text{ Liter}$
 Design Pressure: $PS = 130 \text{ bar}$

$$PS \cdot V = 1807 [\text{bar} \cdot \text{l}]$$

Table 1. Defining the PED category for non dangerous gasses. The red lines indicate the accumulator properties.

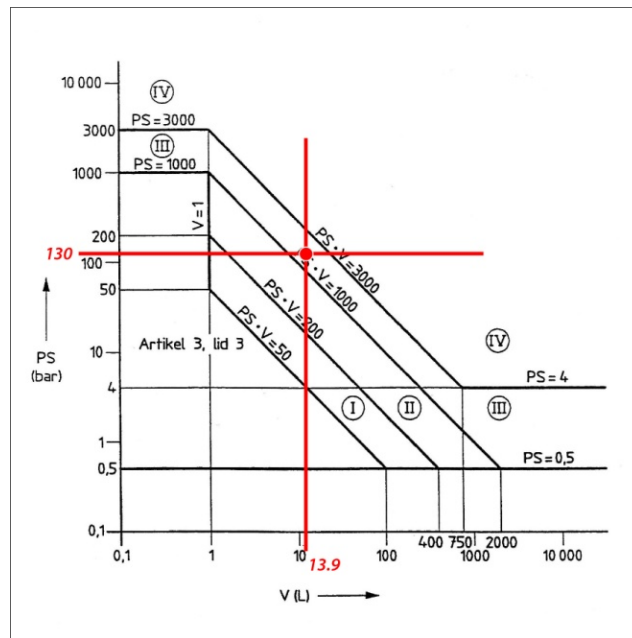

Following Table 1, the accumulator vessel must be classified in *category III*
 The following modules are available: B1+D, B1+F, B+E, B+C1, H

Chosen is to follow modules: **B1+F**

Table 2, The contents of the modules

Module	Description
B1	The manufacturer draws up the technical documentation. The authorized body examines the technical documentation and issues an EEC construction testing certificate.
F	Manufacturers ensure that production conforms to the specifications of the type approval or the construction testing certificate. The authorized body inspects each product. The authorized body issues a certificate of conformity.

See the appendices A to I for all welding certificates, radiographic tests and pressure test reports. The ‘Declaration of Conformity’ of the two accumulators, issued in accordance with the Pressure Equipment Directive (PED) 97/23/CE, can be found at appendix I.

3.2 Heat exchanger with reinforced plates

The SWEP Double wall DBDW16DW heat exchanger itself is generally approved for the Pressure Equipment Directive (PED). The design pressure is 140 bar, with a test pressure of 210 bar. See therefore appendix J for the datasheet.

Two types heat exchanger are used in the CO₂ system:

<i>Name</i>	<i>SWEP type number</i>	<i>Number of plates</i>	<i>Volume (L)</i>
Main	B16DWx12/1P-SC-U	12	0.305
Backup	B16DWx6/1P-SC-U	6	0.122

The reinforced plates are calculated (see paragraph 4.2) with respect to CODAP.

3.3 Damper

Pressure equipment: Pressure vessel
 Media: Carbon dioxide
 Group: Non dangerous media
 Phase: Gas
 Vessel volume: $V = \emptyset 41 \cdot 374 = 15334 \text{ mm}^2 = 1.5 \text{ Liter}$
 Design Pressure: $PS = 130 \text{ bar}$

$$PS \cdot V = 195 [\text{bar} \cdot \text{l}]$$

Table 3. Defining the PED category for non dangerous gasses. The red lines indicate the damper properties.

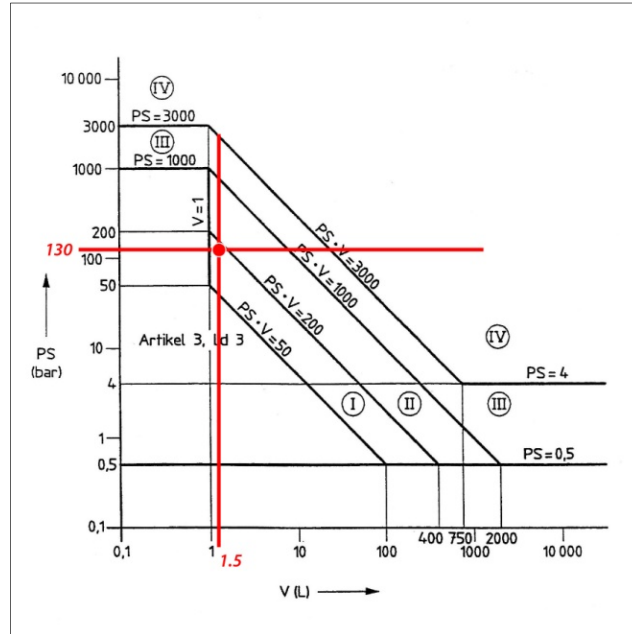

Following Table 3 the damper must be classified in *category I*
 The following module is available: **A**

Table 4. The contents of the module

Module	Descriptor
A	Manufacturers attend to internal manufacturing control, themselves producing and storing the documentation. The authorized body not involved.

4 Calculations (Finite element analysis)

Finite element analyses are done for the accumulator, reinforced plates and damper to investigate the expected stresses and deformations. The French construction code for pressure apparatus (CODAP) is used to verify the stresses.

Following the chosen *construction class B* and *welding coefficient $z=0.7$* , the stress limits according to CODAP are:

- **Global zones:** $f = f_3 = \frac{R_m}{3.5}$
- **Weld regions:** $f_w = \frac{z \cdot R_m}{3.5}$
- **Peak regions:** $f_p = 1.5 \cdot f_3$
- **Peak/Weld regions:** $f_{pw} = 1.5 \cdot f_w$

Finite element analyses are done with the finite element analysis module of Ideas™. Results of the stress analysis are presented in terms of von Mises equivalent stress. In addition the calculated deformations from the stress analysis are presented. The quality of the FEA is verified using the strain energy error norm. A value below 7% is recommended by the IDEAS™ software.

4.1 Accumulator

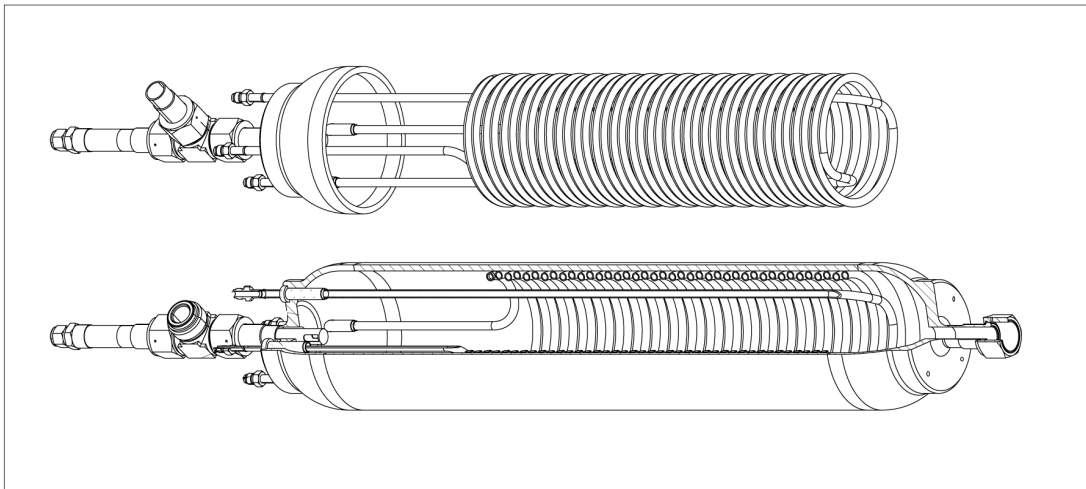

Figure 19, the accumulator pressure vessel with two cooling coils inside.

The accumulator is a stainless steel pressure vessel with a volume of 15.5 liter. Inside this vessel are two coils welded to the bottom part of the vessel. The accumulator vessel consists of three welded parts together. These welds are at the position where stresses are minimal and are full penetrating preventing a weakening of the structure. Drawings TVC51/TVC5104/TVC5105 in Appendix O shows detailed engineering information.

4.1.1 Operational conditions

1/8 of the pressure vessel is modeled, as the vessel is symmetric about YZ and XY, see also Figure 20 - 22.

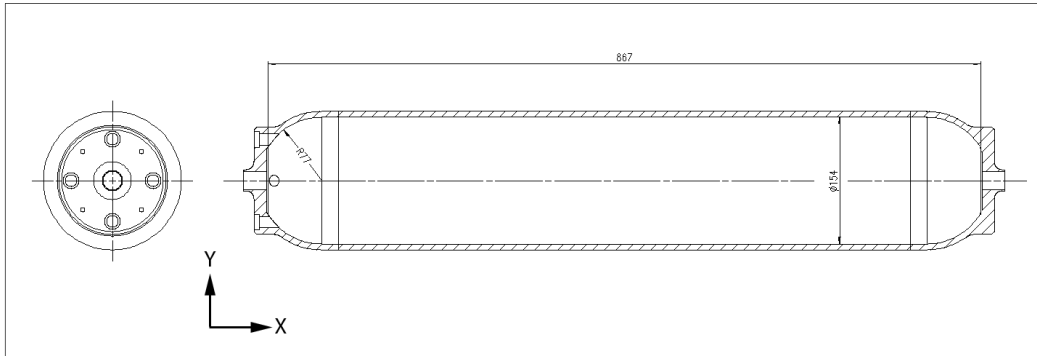

Figure 20. Top view and crossing of the accumulator.

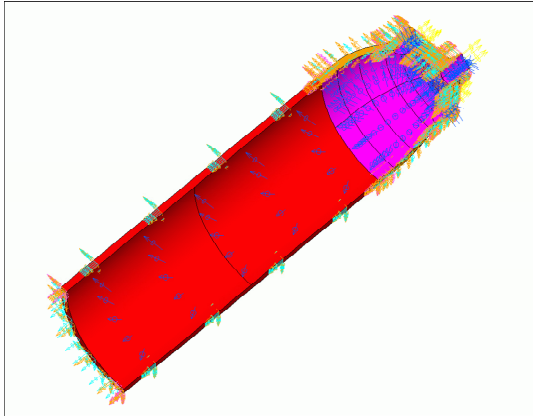

Figure 21. Finite Element Model with symmetry constraints and a pressure load of 130 Bar

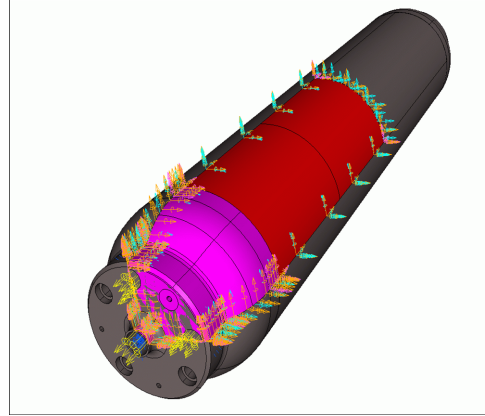

Figure 22. 1/8 part is modeled

The load of the accumulator is 130 Bar (13 MPa). This is determined by the safety disks (burst disks) which opens at 130 Bar. The operational temperature of the accumulator varies between -50...20 degrees Celsius. All the parts of this vessel are connected in such a way that thermal effects have no effect on the load. Also the support of this vessel is designed in such a way that thermal expansion does not induce stresses in the vessel. All loads are applied without any safety factors. The FEA model is built up from 3D solid parabolic tetrahedron.

4.1.2 Material

The accumulators are made from AISI 316L TYPE X2CrNiMo17-12-2 (1.4404). The material has been selected based on the corrosion requirements and the welding ability of the material. A summary of the mechanical properties is given in Table 5

Table 5. Properties AISI 316L.(20-25 °C)

Tensile strength	R _m [MPa]	min.	585
Yield strength	R _{p 0.2%} [MPa]	min.	260
Young's modulus	E [GPa]	min.	200
Density	ρ [g/cm ³]		7.85
Poisons ratio			0.30
Elongation at break	A5 [%]	min.	40
Brinell hardness	HB	max.	180

The stress limits according to CODAP are:

- Global zones: $f = f_3 = \frac{R_m}{3.5} = \frac{525}{3.5} = 150 \text{ MPa}$
- Weld regions: $f_w = \frac{z \cdot R_m}{3.5} = \frac{0.7 \cdot 525}{3.5} = 105 \text{ MPa}$
- Peak regions: $f_p = 1.5 \cdot f_3 = 1.5 \cdot 150 = 225 \text{ MPa}$
- Peak/Weld regions: $f_{pw} = 1.5 \cdot f_w = 1.5 \cdot 105 = 157 \text{ MPa}$

4.1.3 Calculation accumulator tube

Design Pressure: $PS = 130 \text{ bar} = 13 \text{ MPa}$
Inside diameter: $D_{in} = 154 \text{ mm}$
Outside diameter: $D_{out} = 168 \text{ mm}$
Wall thickness: $t = 7 \text{ mm}$

The vessel can be considered as thin-walled vessel because the D_{in}/t ratio ($154/7=22$) is higher than 10 (often cited as 20).

$$\text{Radial (Hoop) stress: } \sigma_r = \frac{F}{A} = \frac{PS \cdot D_{in}}{2 \cdot t} = \frac{13 \cdot 154}{2 \cdot 7} = 143 \text{ MPa}$$

$$\text{Axial stress: } \sigma_a = \frac{F}{A} = \frac{PS \cdot D_{in}^2}{D_{out}^2 - D_{in}^2} = \frac{13 \cdot 154^2}{168^2 - 154^2} = 68.4 \text{ MPa}$$

$$\text{Equivalent stress } \sigma_v = \sqrt{\sigma_r^2 + \sigma_a^2} = 158.5 \text{ MPa}$$

4.1.4 Stress and deformation analysis

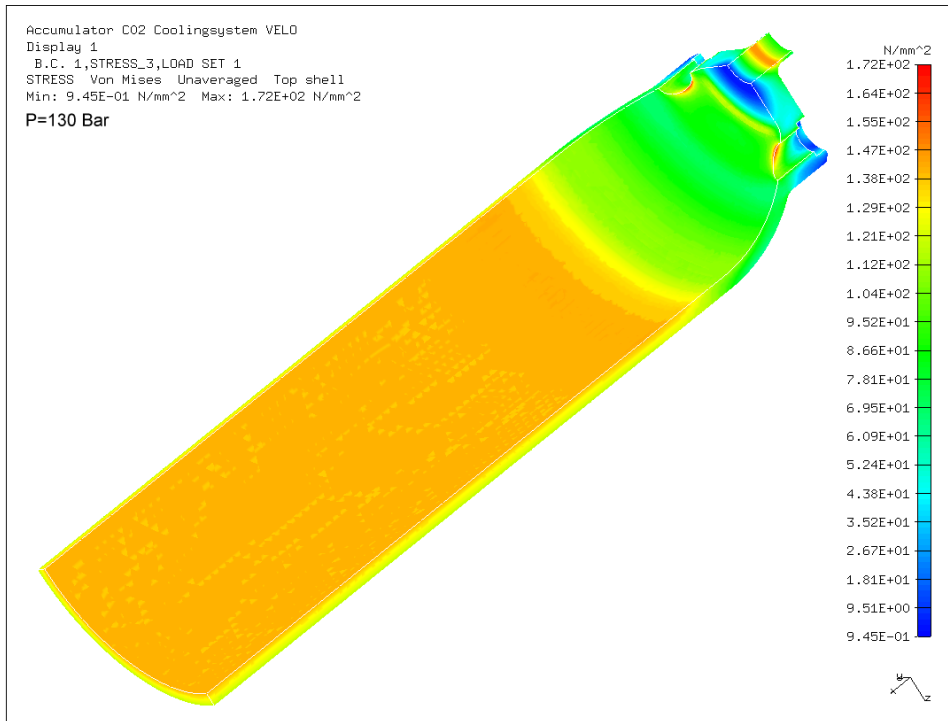

Figure 23. Stress result of the accumulator. Inside view

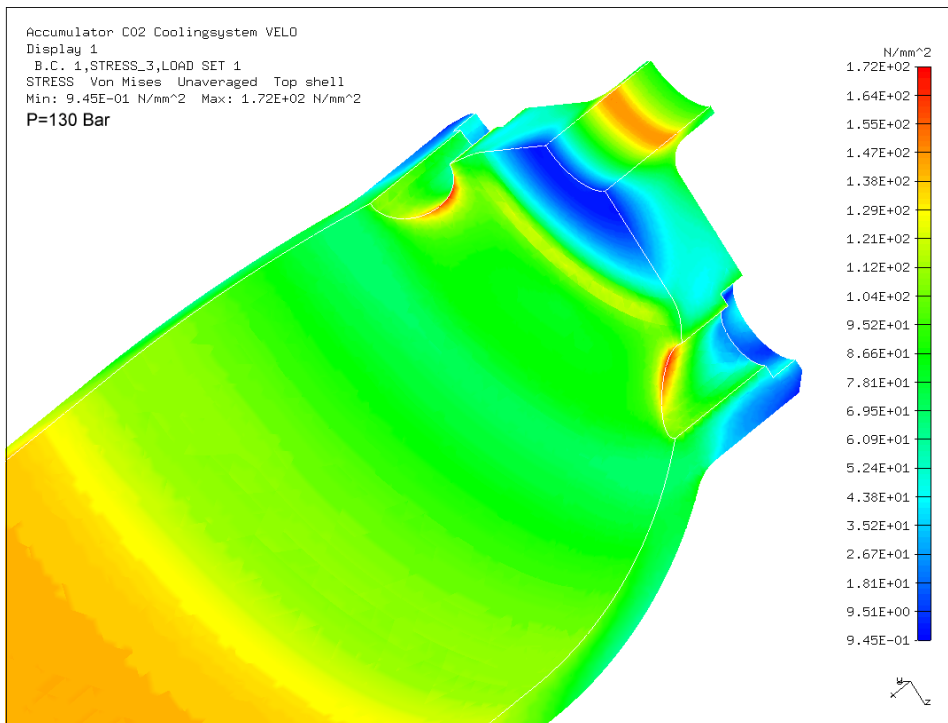

Figure 24. Detail stress inside accumulator

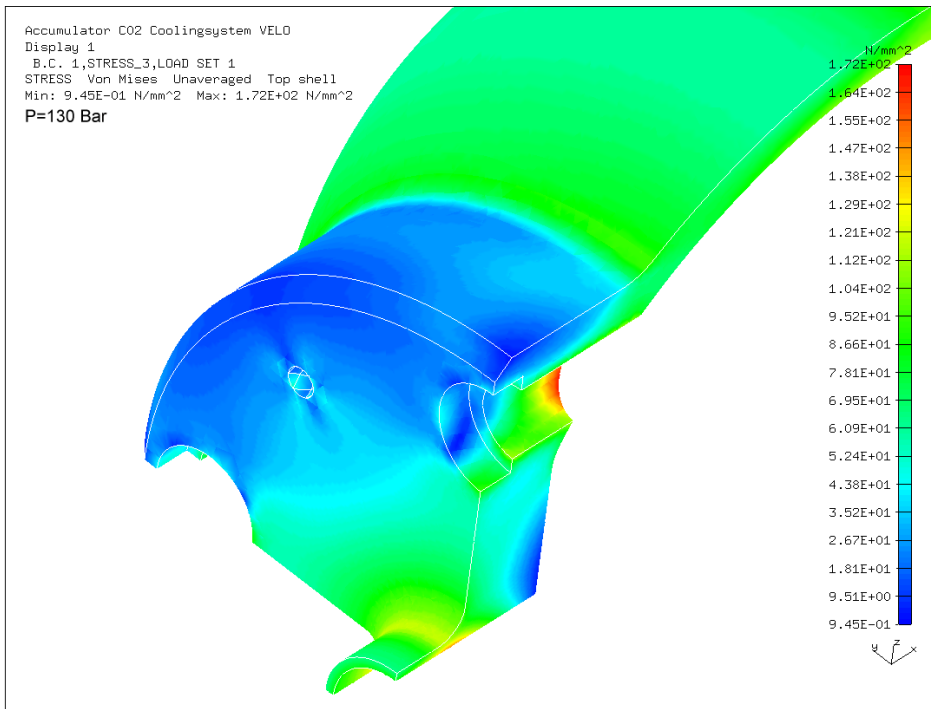

Figure 25. Detail stress outside accumulator

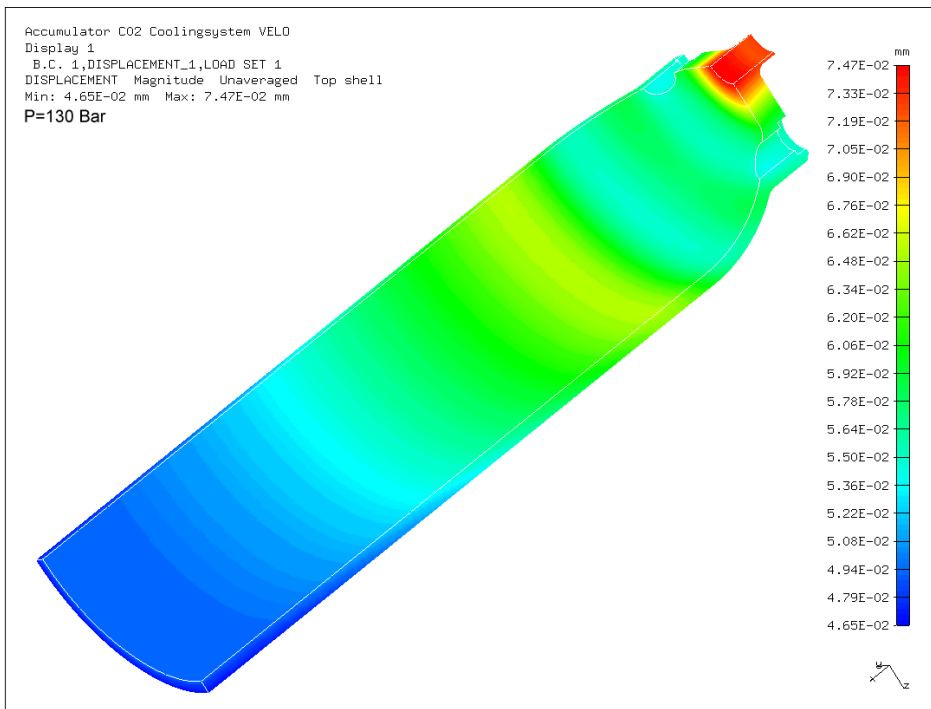
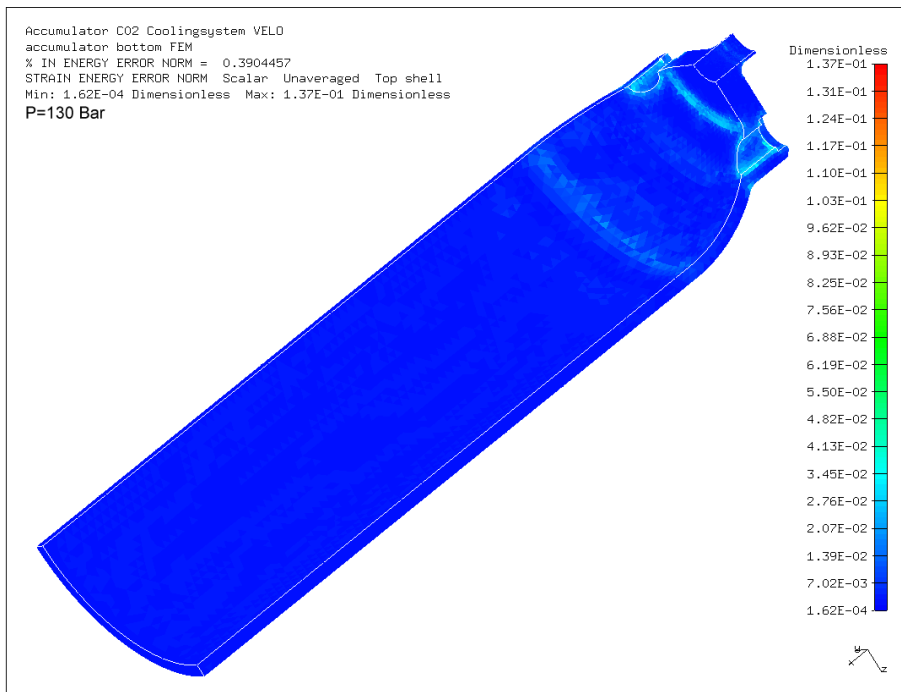
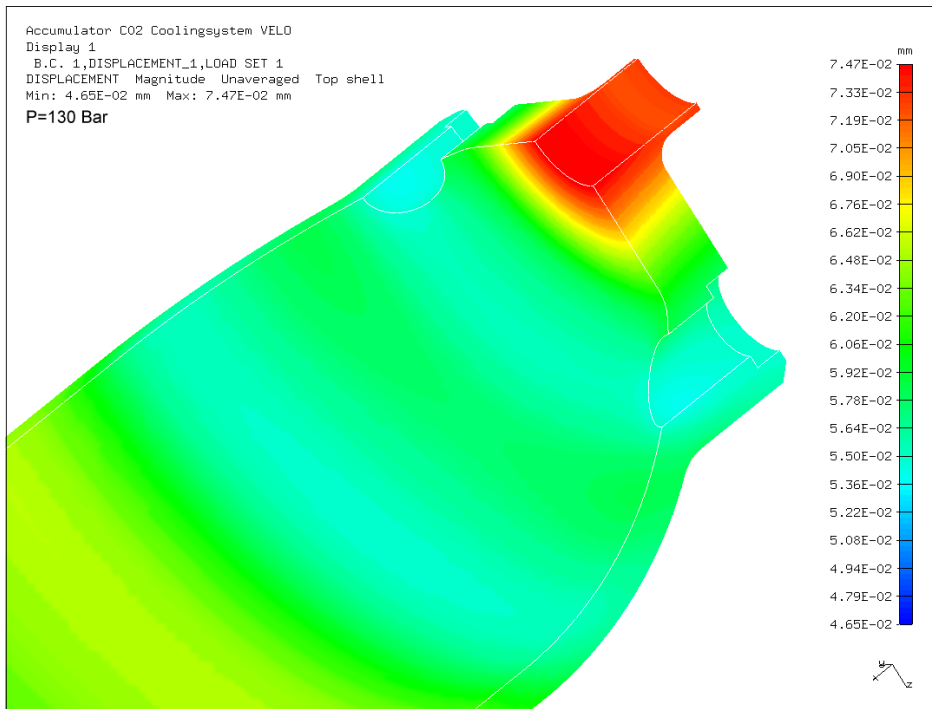

Figure 26. Deformation result of the accumulator. Max = 0.07 mm



4.2 Reinforced plates of the heat exchanger

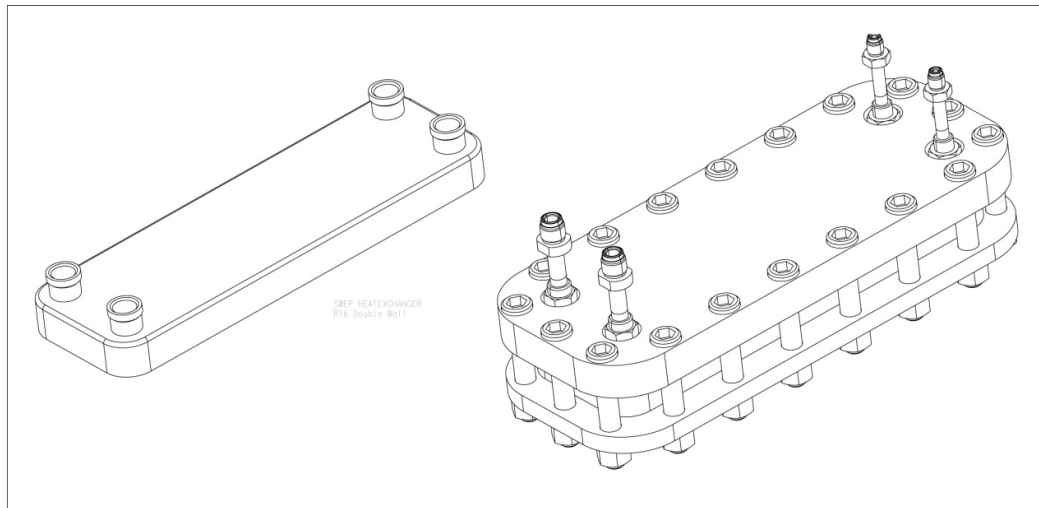

Figure 29. Swep 'double wall' heat exchanger with reinforced plates

The SWEP *double wall* heat exchanger is reinforced with two stainless steel plates (AISI 304) and bolted together with eighteen M16 bolts and nuts (Steel grade 8.8). Drawings TVC72/TVC7201/TVC7202 in Appendix O shows detailed engineering information. See appendix J for the SWEP data sheet.

4.2.1 Operational conditions

The load on the two reinforced plates is 130 Bar (13 MPa). This is determined by the heat exchanger which is connected to the CO₂ system. The support of the heat exchanger is designed in such a way that thermal expansion does not induce additional stresses. All loads are applied without any safety factors. The FEA model is built up from 3D solid parabolic tetrahedron. A quarter of the two reinforced plates are modeled as the plates are symmetric about the two axes.

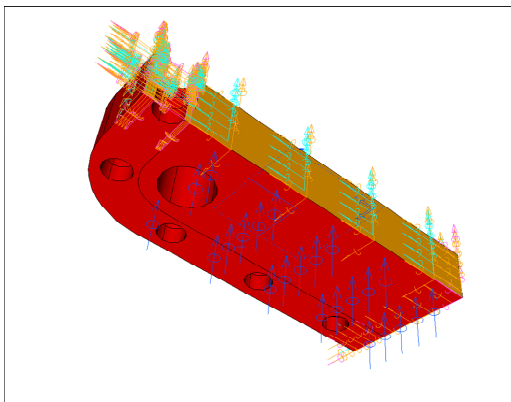

Figure 30. FEA Model of the top plate with symmetry constrains and a pressure load of 130 Bar

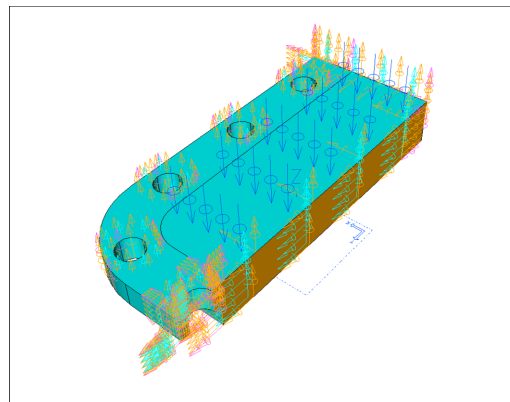

Figure 31. FEA model of the bottom plate

4.2.2 Material

The reinforced plates are made from AISI 304. The material has been selected based on the corrosion and machining requirements. The bolts are made of steel grade 8.8 (zinc plated) based on the high tensile strength properties. A summary of the mechanical properties are given in Table 6 and 7.

Table 6. Properties AISI 304 (20-25 °C)

Tensile strength	R _m [MPa]	min.	515
Yield strength	R _{p 0.2%} [MPa]	min.	205
Young's modulus	E [GPa]	min.	193
Density	ρ [g/cm ³]		8
Poisons ratio			0.25
Elongation at break	A5 [%]	min.	40
Brinell hardness	HRB	max.	88

Table 7. Properties Steel grade 8.8 (10-35 °C)

Tensile strength	R _m [MPa]	min.	800
Yield strength	R _{p 0.2%} [MPa]	min.	660
Young's modulus	E [GPa]	min.	200
Elongation at break	A5 [%]	min.	12
Brinell hardness	HRC		23-34

The stress limits in the reinforced plates according to CODAP are:

- Global zones: $f = f_3 = \frac{R_m}{3.5} = \frac{515}{3.5} = 147 \text{ MPa}$
- Peak regions: $f_p = 1.5 \cdot f_3 = 1.5 \cdot 147 = 220 \text{ MPa}$

4.2.3 Stress and deformation analysis

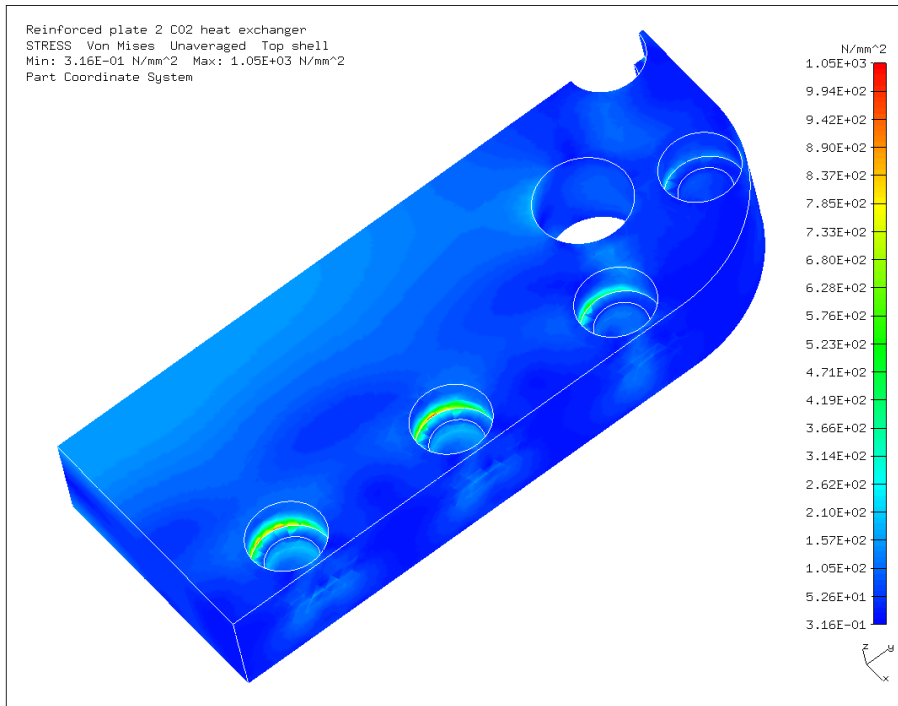

Figure 32. Stress result of the top plate

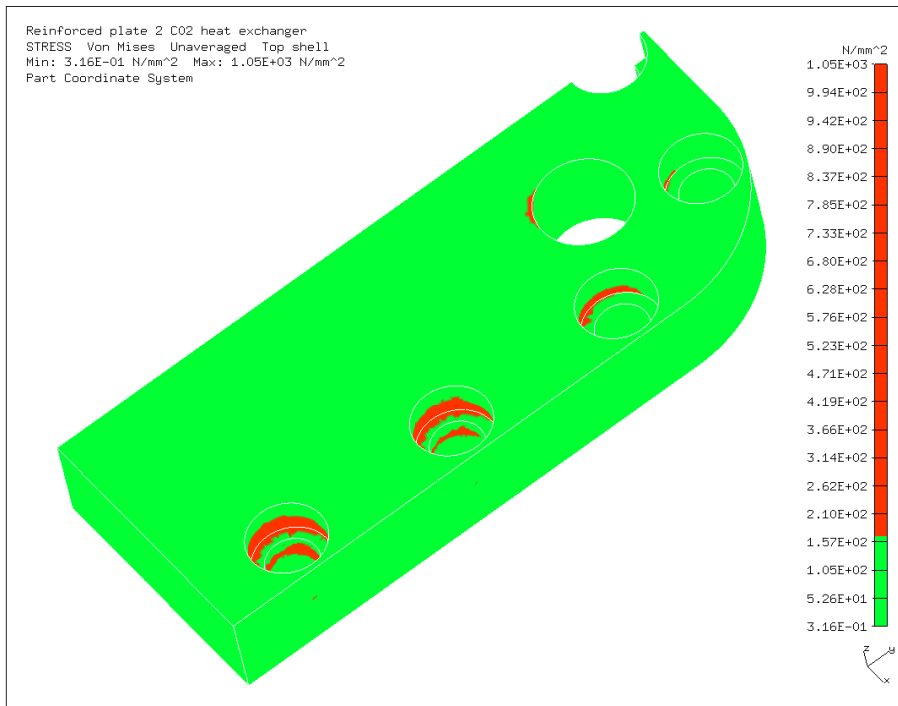

Figure 33. Stress result limited to 147 MPa

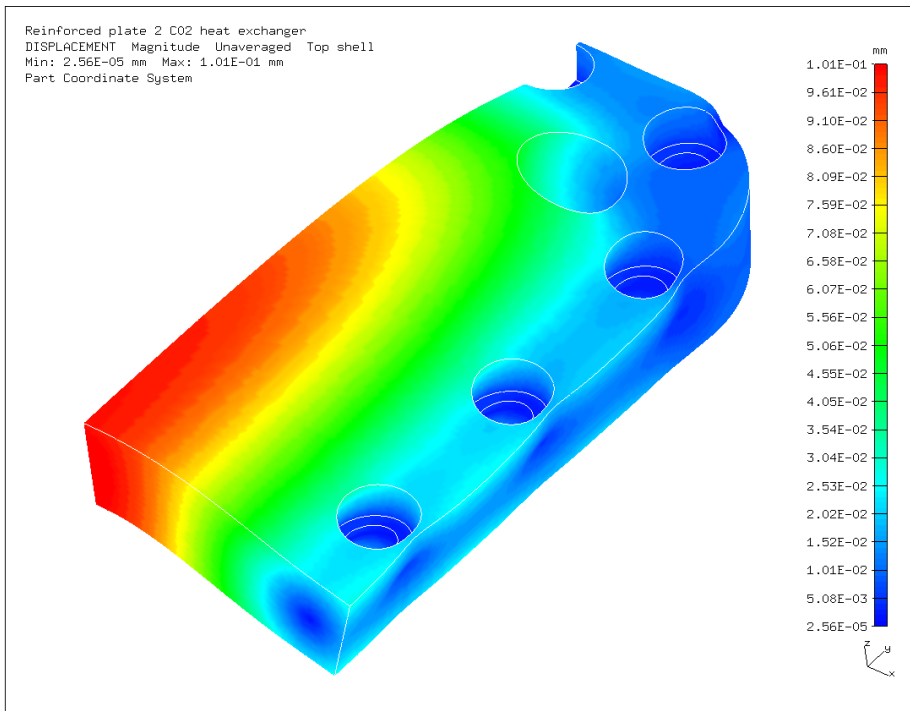

Figure 34. Deformation result. Max = 0.1 mm

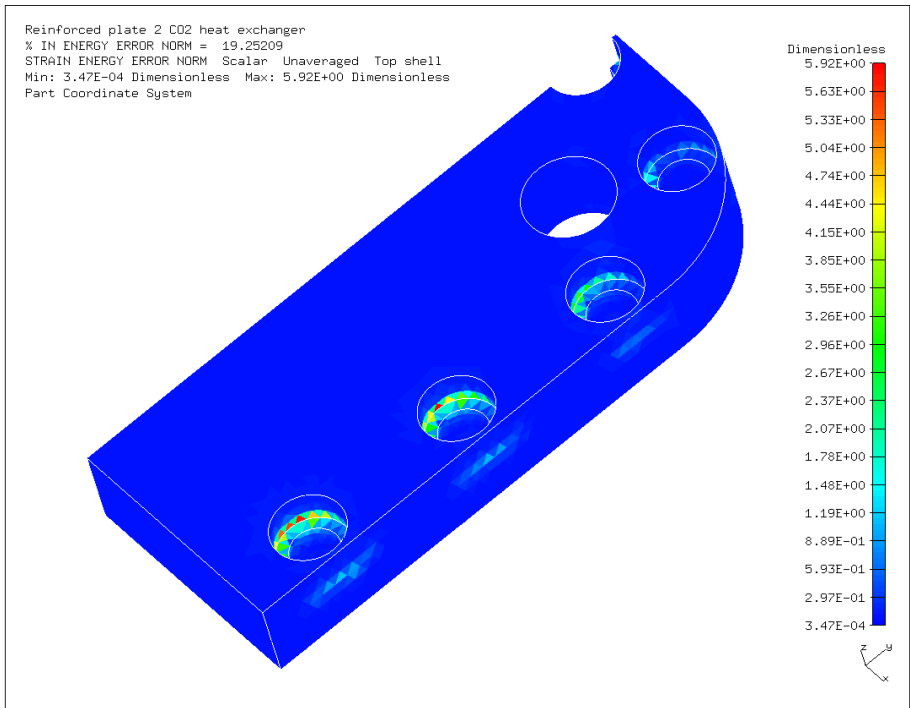

Figure 35. . 'Strain energy error norm' of top plate (19%)

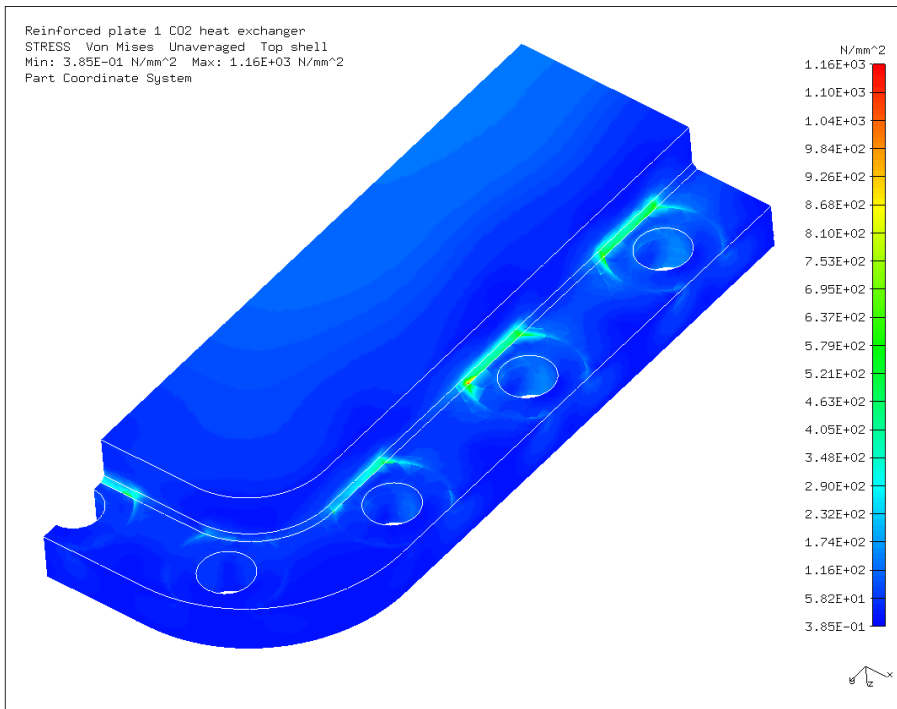

Figure 36. Stress result of bottom plate

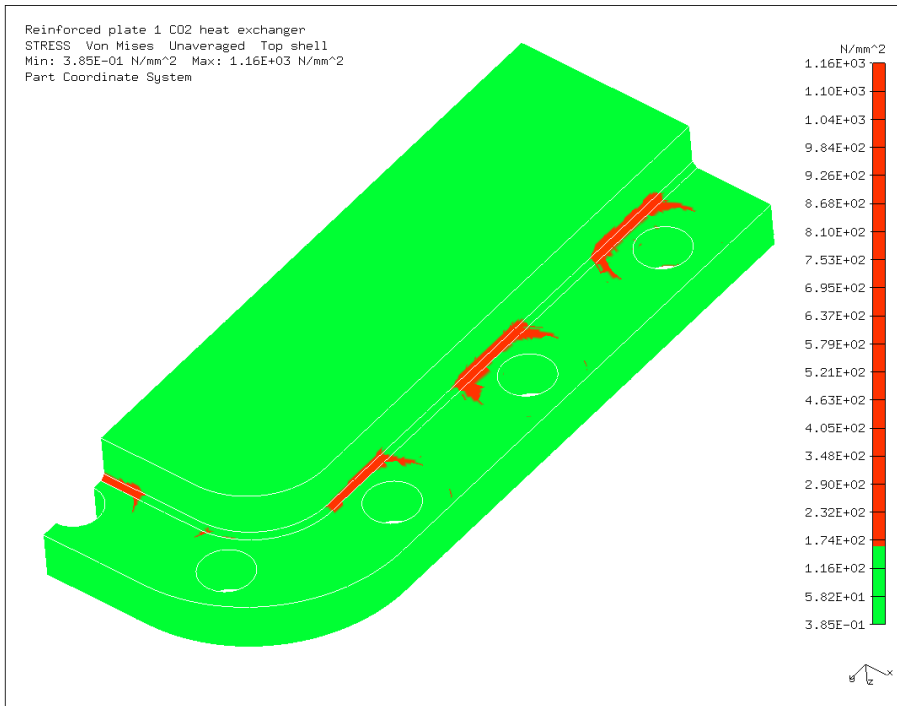

Figure 37. Stress result limited to 147 MPa

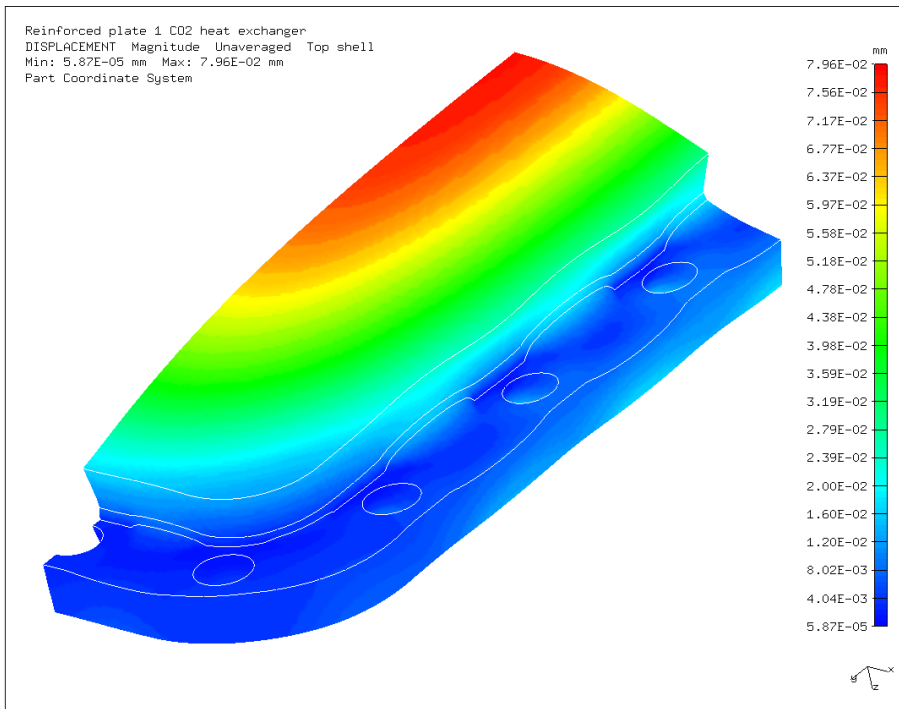

Figure 38. Deformation result. Max = 0.08 mm

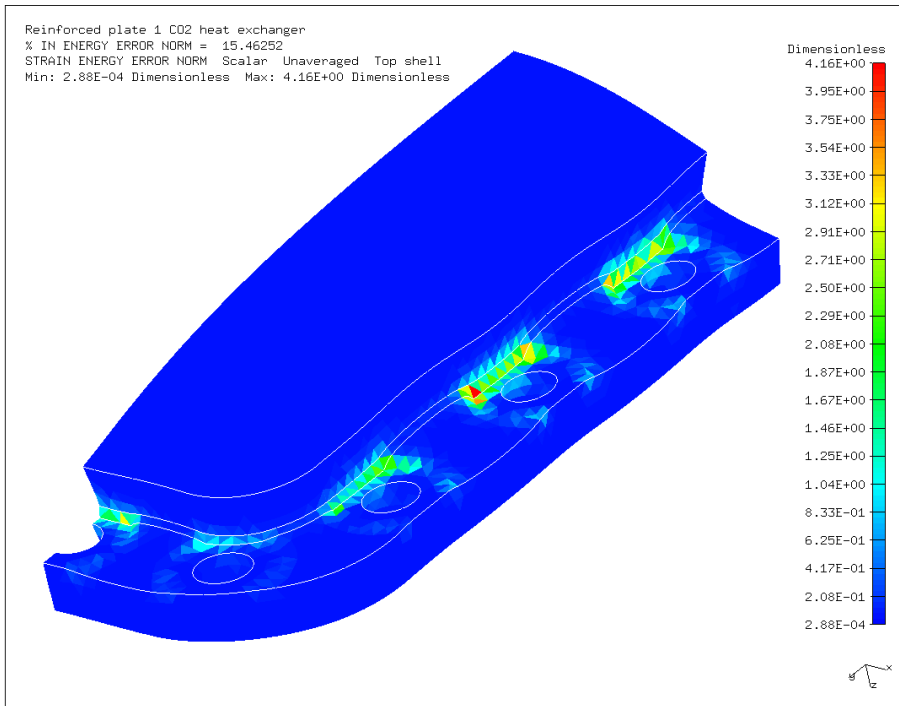

Figure 39. 'Strain energy error norm' of bottom plate (15%)

4.2.4 Calculation of the bolts

Number of bolts: 18
Bolt material: Steel grade 8.8
Bolt dimension: M16
Pressure **P**: 130 bar (13 MPa)
Pressure surface **A_p**: 42550 mm²
Safety factor **S**: 0.6

Core diameter **D_k** of a M16 bolt = 13.5 mm

$$\text{Core surface } A_c = \frac{\pi \cdot D_k^2}{4} = \frac{\pi \cdot 13.5^2}{4} = 143 \text{ mm}^2$$

$$\text{Force per bolt } F_b = \frac{P \cdot A_p}{18} = \frac{13 \cdot 42550}{18} = 30.73 \text{ kN}$$

$$\text{Admissible tensile strength } R_\alpha = S \cdot R_{p0.2\%} = 0.6 \cdot 660 = 396 \text{ MPa}$$

$\text{Present Tensile Stress } \sigma_t = \frac{F_b}{A_c} = \frac{30730}{143} = 214 \text{ MPa}$

4.3 Damper

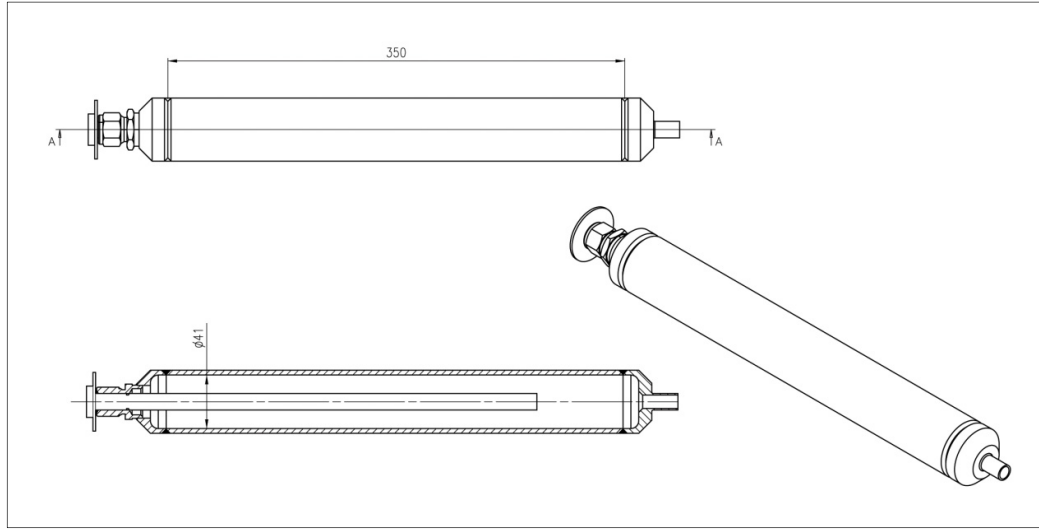

Figure 40. Damper

The damper is a stainless steel pressure vessel with a volume of 1.5 liter. The damper consists of three welded parts together. These welds are at the position where stresses are minimal. Inside the damper a WATLOW electric heater (220 Volt) is mounted. This heater has an internal thermocouple and controlled by the general PLC. Drawing TVC54 in Appendix O show detailed engineering information.

4.3.1 Operational conditions

The load of the damper is 130 bar (13 MPa). This is determined by the safety disks (burst disks) which open at 130 bars. The operational temperature a damper varies between +20 and -50 degrees Celsius. All the parts of this vessel are connected in such a way that thermal effects have no effect on the load. Also the support of this vessel is designed in such a way that thermal expansion does not induce stresses in the vessel. All loads are applied without any safety factors. The FEA model is built up from 3D solid parabolic tetrahedron. A quarter of the damper is modeled as the damper is rotational symmetric, see also Figure 41 and 42.

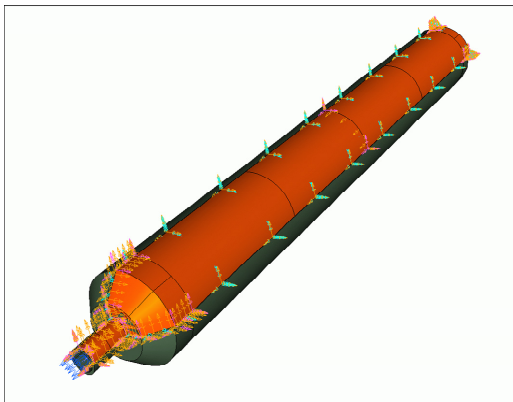

Figure 41. A quarter of the damper is modeled

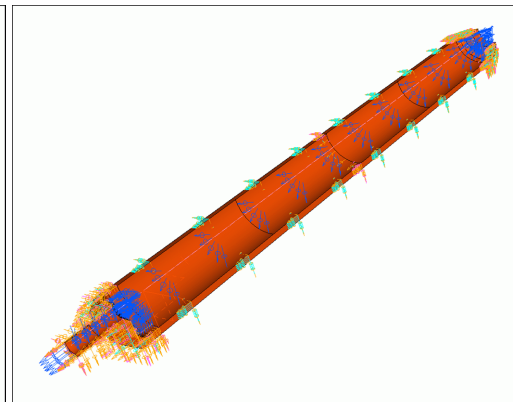

Figure 42. The FEA Model with symmetry constraints and a pressure load of 130 Bar

4.3.2 Material

The dampers are made from AISI 316L TYPE X2CrNiMo17-12-2 (1.4404), the same material as the accumulators are made from. The material has been selected based on the corrosion requirements and the welding ability of the material. See paragraph 4.1.2 at page 16 for the material properties

4.3.3 Stress and deformation analysis

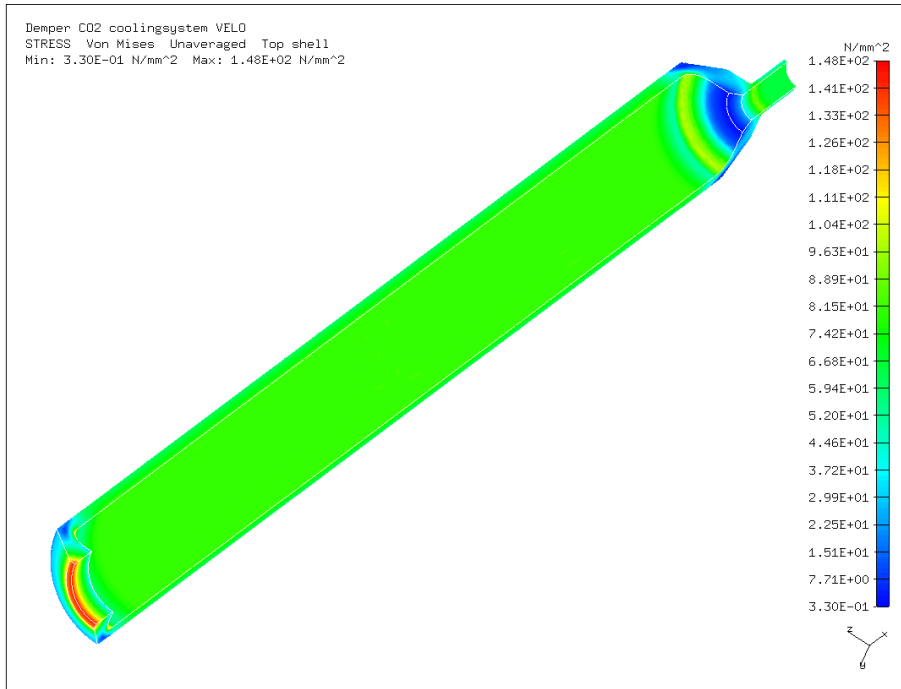

Figure 43. Stress result of the damper. Max = 148 MPa.

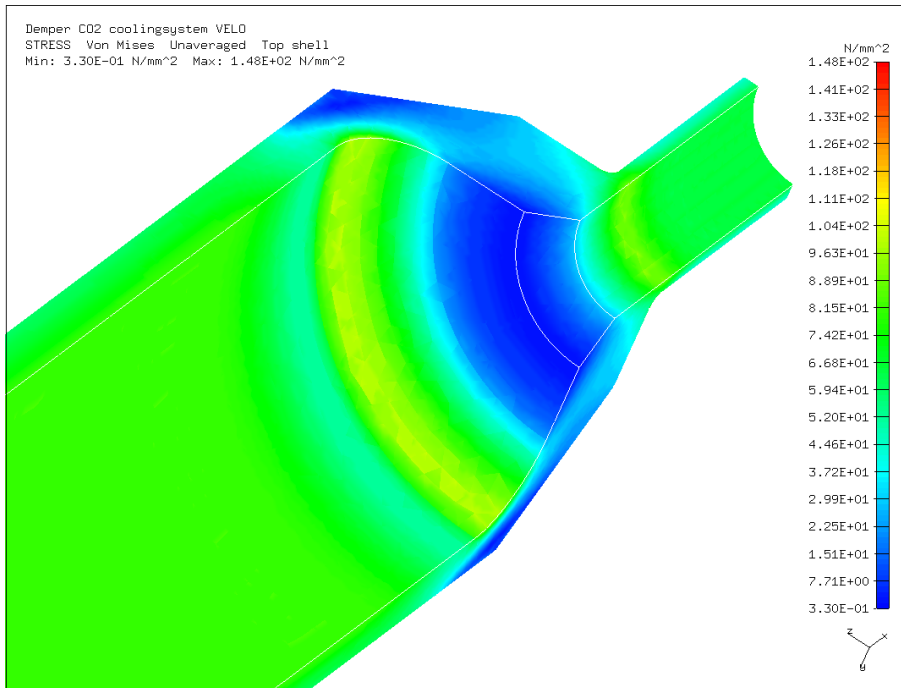

Figure 44. Detail stress result.

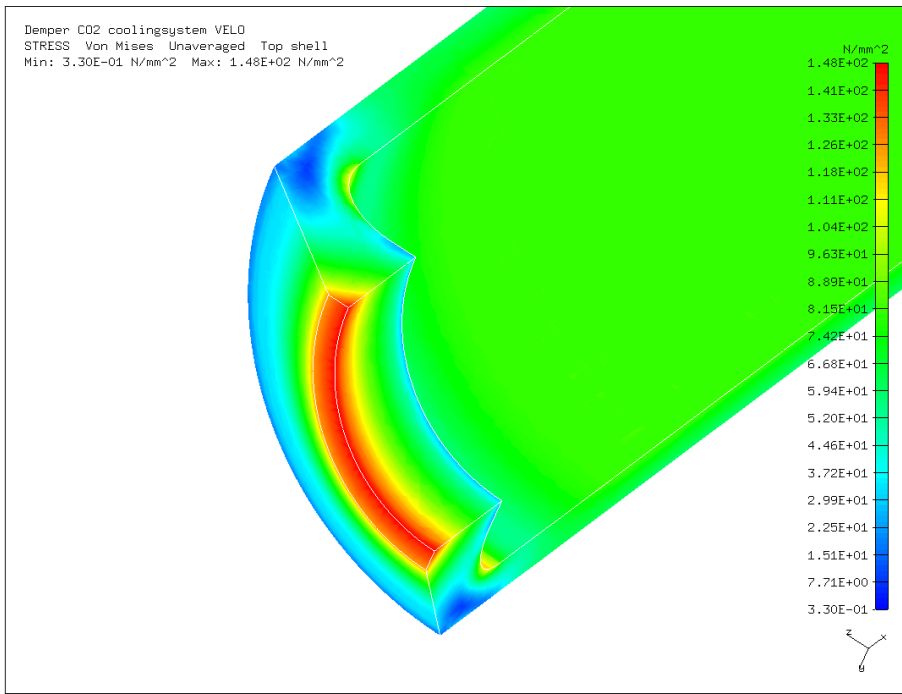

Figure 45. Detail stress result.

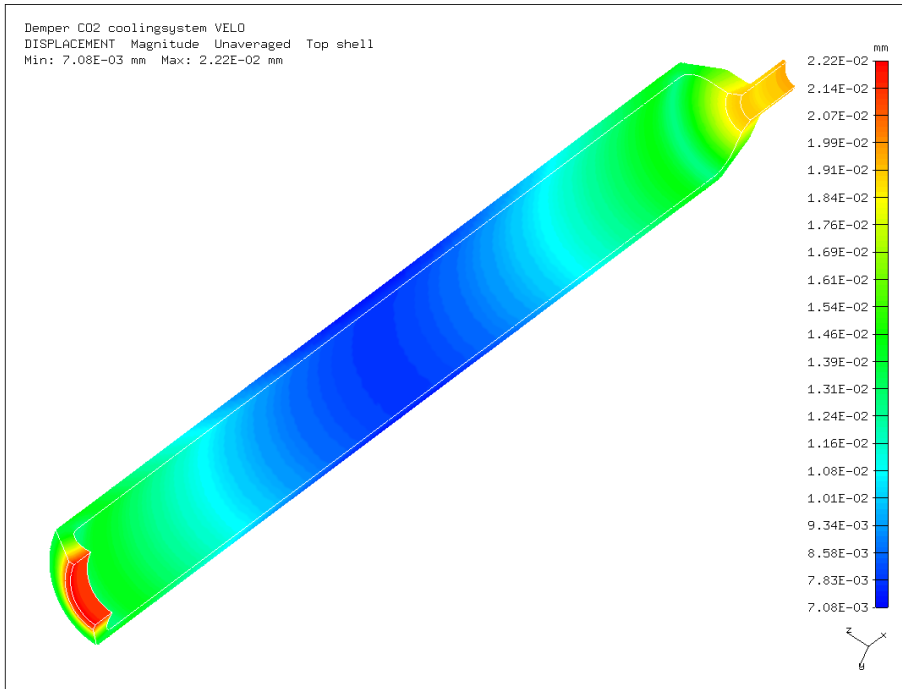

Figure 46. Deformation result of the damper. Max. = 0.02mm

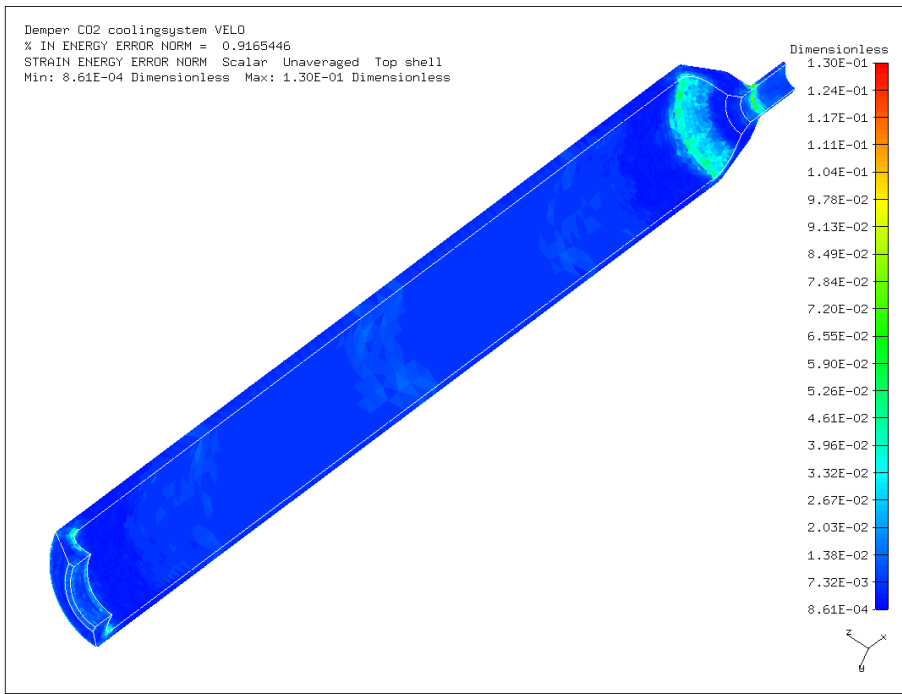

Figure 47. 'Stain energy error norm' of the damper (0.9%)

4.4 Results of the analysis.

The results are compared with the requirements defined by the CODAP. The limitations of the analysis are presented, and the compliance with the code is verified.

4.4.1 Accumulator

The general stresses in the accumulator are well below the acceptable values (150 MPa). Also the stress in the weld regions (max 90MPa) are well below the CODAP limit of 105 MPa. There are some peak stresses (170 MPa) in the corners of the coil connections (see Figure 24 at page 18) but they are also far well below the acceptable value of 225 MPa.

The global value for the strain energy error norm in the accumulator is low (0.4 %) and far below the 7% which is recommended by the IDEAS™ software.

4.4.2 Reinforced plates of the heat exchanger

The general stresses in the reinforced plates are well below the acceptable values of 147 MPa.

4.4.3 Damper

The general stresses in the Damper are below the acceptable values of 150 MPa. There is a peak stress at the bottom of the damper (148 MPa) due to the simulation constrains. Although this peak stress will be lower in 'real life' this peak of 148 MPa is far below the acceptable value of 225 MPa.

5 Tests, safety and quality control

The test, safety and quality control are the steps taken to ensure a safe operation of the system.

5.1 Tests before installation at CERN

The test pressure used for all components is given by CODAP 95 (E) – 1/36 by the formula:

$$P_{test} = 1.30 \cdot P \frac{fe}{ft} = 1.30 \cdot 130 \text{ Bar} \cdot 1 = \mathbf{169 \text{ Bar}}$$

Where:

P = design pressure for a normal condition which is the most severe under pressure

fe = nominal design stress for a normal operating condition at the temperature of the test

ft = nominal design stress for a normal operating which is the most severe under pressure at the corresponding design pressure.

Accumulators

Separated pressure tests on the two accumulators at 170 bar is performed by RUCH ARMADAC BV CALIBRATION LABORATORY. See appendix H for details.

CO₂ plant

The whole CO₂ plant (with accumulators, dampers, heat exchangers and the cooling bridge) is pressure tested at 170 bar for 5 minutes by the firm RUCH, see appendix D for details.

Freon plant

The Freon cooler is pressure tested at 23 bar for 24 hours by the manufacturer, Wagenaar Koeltechniek in the Netherlands. See appendix L for details.

5.2 Tests at CERN

Transferlines

The two transfer lines (concentric tubes of about 50 meter long) which runs from the platform, where the cooling system is installed, to the alcove where the VELO is installed are pressure tested to 125 bar during 15 minutes. The system was also leak tested. The certificates of these tests can be found in at appendix M.

CO₂ plant

When the system was completely installed at CERN (the CO₂ system connected to transfer line) it was be tested for leaks. The system is filled with N₂ and during a couple of hours the pressure was monitored. No leaks were present and no pressure decays has be seen.

5.3 Safety

5.3.1 Safety valves

To prevent failure of the system, the system is equipped with burst discs and two relief valve. The burst disc will open at 130 +/- 8% bar absolute pressure. The relief valves are adjust and tested at Nikhef that it opens at 130 bar.

5.3.2 Personal safety

The system will contain about 2 x 15kg of CO₂ and a few kg of R507a (about 3kg for the backup chiller and about 5.5kg for the main chiller), the same gas used as in a freezer. If a leak occurs (at the burst disks, different joints, ...) the maximal amount of gas that can escape is limited. Therefore no extra Oxygen Deficiency detectors are installed. The only confined space like area, where a potential gas leak could occur is in the alcove under the VELO detector platform. This is an area where occasional access is needed during shutdowns for service work. People will be required to take a personal CO₂ meter (C1100 OLDHAM) with them when carrying out work in this area when the cooling system is operational.

Use of special cryogenic equipment (safety goggles and gloves) will be proscribed when intervention and service work on the cooling system is needed.

5.3.3 Internal interlocks and protections

Heater protection

The heaters in the system (for the pumps, bypass heater and the accumulator) are protected by hardware and software. Whenever a limit of 130°C (measured by the clixons thermostats) is exceeded all heaters will be switched off. The PLC monitors the individual heater temperatures by PT100 sensors. Whenever the limits as given in Table 8 are exceeded the PLC switches off all heaters.

Table 8. The threshold values of the different heaters in the system TL/TR means either the heater in the left or right system

Heater name	Threshold value (°C)
TL/TR_HT101	100
TL/TR_HT102	40
TL/TR_HT103	100
TL/TR_HT104	80
TL/TR_HT105	120
TLR_HT102	40

Pressure protection

The pressure of the accumulator can be increased by external temperature rises or by accidental overheating of the accumulator heater. The pressure is measured, and when a pressure threshold is reached the accumulator heater is switched off.

The 3 pumps have an internal mechanical safety mechanism for overpressure set at 100 bar. However, the PLC monitors the pressures in different sections of the systems.

When the pressure after the pump gets too high (discharge pressure), the pump will be switched off. When the pressure difference over the pump (Δp or pump pressure head) stays below a threshold the pump will be switched off. An extra check is made to verify that the valve between accumulator and system is not closed. At start up the pump has to build up this pressure first, so the threshold has to be reached within a certain time limit. An overview of the different threshold values is given in Table 9. To protect the membranes of the pumps a membrane alarm is given at a pressure of 10 bar. Whenever this threshold is exceeded the pump concerned stops running.

Table 9. The threshold values for the pressure protection of the system

Pressure sensor name	Threshold value (bar)	Action taken
TR/TL_PT102	>75	Switch accu heater off
TR/TL_PT104 (discharge pressure)	>100	Switch off pump
$\Delta p = TR/TL_PT104 - TR/TL_PT102$ (pump pressure head) OR Check valve TR/TL_VL104	<3 (at startup 10sec delay is given) open	Switch off pump
Δp (pump pressure head)	>25	Switch off pump

Compressor protection

The compressors of both main and backup chiller are hardware wise protected by pressostats. Whenever the discharge pressure exceeds a certain limit or the suction pressure goes below a certain threshold the compressor will be stopped.

The limits and sensors are different for main and backup chiller and are given in Table 10.

To avoid liquid in the compressor the temperature measured by sensor 121 (suction temperature) should be larger than the saturation temperature corresponding to the suction pressure (measured by SA_PT107 for the main chiller and by SB_PT103 for the backup chiller). Whenever this condition is not fulfilled the compressor is stopped.

Table 10. The threshold values for the chiller protection

Pressure sensor name	Threshold value	Action taken
SA_PT108	< 0.7 bar or > 20 bar	Stop compressor
SB_PT108	< 0.9 bar or > 20 bar	Stop compressor

5.4 Quality control

Tubing

Quality control during manufacturing of all tubing is based on the controlled welding procedure with a Swagelok orbital welding machine. Before each final orbital welding tests with the same tube and material were done to optimize the welding parameters.



Figure 48. Swagelok orbital welding machine



Figure 49. Test weld

accumulators

The material certificates used in the accumulators is listed in appendix G
Two main welds of the two accumulators are done by the ISO 9001:2000 certificated firm 'Hoefnagel & Meijn B.V'. See appendix D, E and F for the ISO 9001:2000 certificate, the welder qualification and welding procedure approval record.
The accumulators are radiographic tested by the 'Röntgen Technische Dienst BV (RTD)'. See appendix A for details. The EN 17020 DAP and EN 473/347 certificates of the RTD can be found in appendix B and C

6 Summary

Presented is the safety analysis of the three main components (accumulator, reinforced plates of the heat exchanger and the damper) in the CO₂ cooling system of the LHCb VELO experiment. The cooling system must comply with the Pressure Equipment Directive (PED) 97/23/CE. The French construction code for pressure apparatus (CODAP) is used to verify the stresses. The design condition of the system is between +25 and -40 °C and a maximum internal pressure of 130 bar. The system is equipped with burst discs and relief valve which opens at 130 bar absolute pressure.

The accumulator vessels are classified in PED *category III*. Chosen is to follow the PED modules: **B1+F**. The dampers are classified in PED *category I* (module A). The SWEP heat exchanger is generally approved for PED. The reinforced plates are calculated with respect to CODAP.

The accumulators and dampers are made of AISI 316 L. Especially for the two accumulators the material is verified upon delivery. The quality of the welding in de accumulator material is verified by means of radiographic testing and a final pressure test of 170 bar is performed. Also the whole CO₂ plant with the cooling bridge is tested at 170 bar. The transfer tubes were pressure tested at CERN to 125 bar during 15 minutes.

To prevent failure of the system, the system is equipped with burst discs and two relief valves (adjust and tested to open at 130 bar). The burst disc will open at 130 +/- 8% bar absolute pressure